



CAPRICORN

General Information

Vessel Name Capricorn
 Type Harbour Tug
 Classification Bureau Veritas I \square HULL \bullet MACH Tug
 (Bollard pull = 70 t) Unrestricted Navigation
 AUT UMS Inwater Survey COMF-NOISE 3,
 COMF-VIB 3
 Fire Fighting Ship 1 with water spray
 For vessels with a sailing time <4 h from a
 safe sheltered anchorage

IMO Number 9993195
 Year Built 2024 - Vietnam
 Flag Sri Lanka
 Call Sign

Dimensions

Length Overall 22.81m
 Beam Overall 12.03m
 Depth at Sides 4.30m
 Draught aft 5.60m
 Displacement 491 tons
 (98% consumables)

Tank Capacity

Fuel Oil (Incl. Long Range Tanks) 79.6m³
 Fuel Oils 51.2m³
 Fresh Water 8.00m³
 Sewage 5.10m³
 Dirty Oil 1.50m³
 Lubrication Oil 1.50m³
 Bilge Wter 3.00m³
 Foam 6.10m³

Performance

Bollard Pull 70 tons
 Bollard Pull 64 tons
 Speed 12.5 knots

Propulsion System

Main Engines 2x Caterpillar 3512C TA HD/D
 Total Power 3804 bkW (5102 bhp) at 1800 rpm
 Azimuth thrusters Kongsberg Maritime US 205S
 Clutches (on-off type) Kongsberg Maritime 'built in' type or equal
 Propeller Diameter 2800 mm
 Forced Ventilation 60.750 m³/h
 IMO Tier III Vessel is prepared for installation of an
 optionally available Class approved Selective
 Catalytic Reduction system

Deck Equipment

Anchor 1x 360 kg Pool (High Holding Power)
 Anchor winch 10 m/min
 Towing Winch Hydraulically driven double drum, pull 35t up to 10
 m/min and maximum speed up to 40 m/min on
 second layer, 175 ton brake on 2nd layer Electrically
 driven, 5 ton at 16 m/min
 Capstan
 Fendering D-fender at sides, cylindrical fender at transom
 corners, cylindrical and W-block bow fender and 6
 heavy fender tyres are fitted on the fore ship

Navigation Equipment

Searchlights 2x Norselight SH470 2000 W
 Radar System Furuno FAR 1518-BB
 ECS MaxSea TZ Professional
 Compass Cassens & Plath Reflecta 11
 Satellite Compass/GPS Simrad GN70/HS80A
 Autopilot Simrad AP-70
 Echosounder Furuno FCV-628
 VHF Radio Telephone 2x Cobham Sailor 7222, one with DSC
 VHF Portable (GMDSS) 2x Sailor SP3540
 Navtex Furuno NX-700B
 AIS Furuno FA-170
 EPIRB Jotron Tron-60AIS
 SART Jotron Tron AIS
 Remote Monitoring Ready for Damen Triton
 Anemometer Gill Instruments GMX 500

Auxiliary Equipment

Generator Sets 2x shaft generator, approx.. 50kW each, 400 V,
 Harbour Generator Set 50 Hz
 Bilge Pump Caterpillar C4.4, 64.5 kVA, 400 V, 50 Hz
 General Service Pumps Azcue CA-32/05 up to 10 m³/h
 Fuel Oil Pump 2x Azcue CA-50/3A up to 27 m³/h
 Fuel Oil Filters Azcue MR-41/10 up to 12.0 m³/h
 Fuel Oil Purifiers 2x Coalester filters incl. water separator
 Bilge Water Separator 2x CJC PTU3 27/81 MZ-E2PWZ, 1920 l/h each
 Fresh Water Pressure Facet CPS-2.5 B MK III + EBM14X1, up to 0.5
 Set m³/h
 Sewage Treatment DAB Euroinox 40/50T, 70 l/min, up to 3.0 bar
 Plant Selmar Blue Sea Plus 2500
 Cooling System Box cooling and keel cooling + anti-growth
 Hydraulic System system
 Double main engine driven pumps

FIFI 1 System

Fifi Set 2x Main engine driven pump 1200 - 1400
 Fifi monitor m³/h
 2x 1200 m³/h water/foam

Accommodation

Person 6
 Air Conditioned Yes

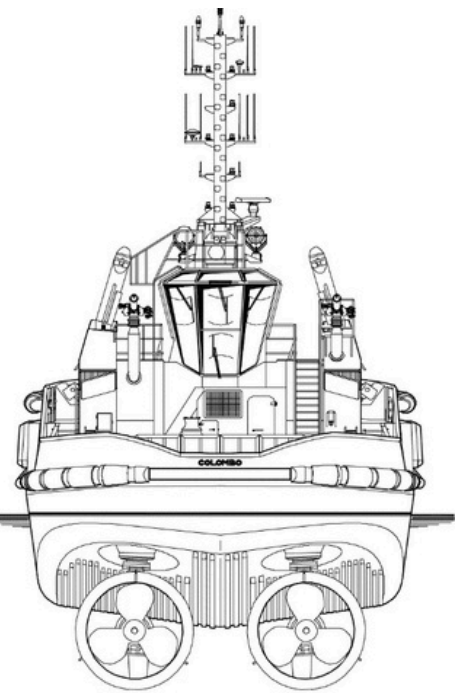
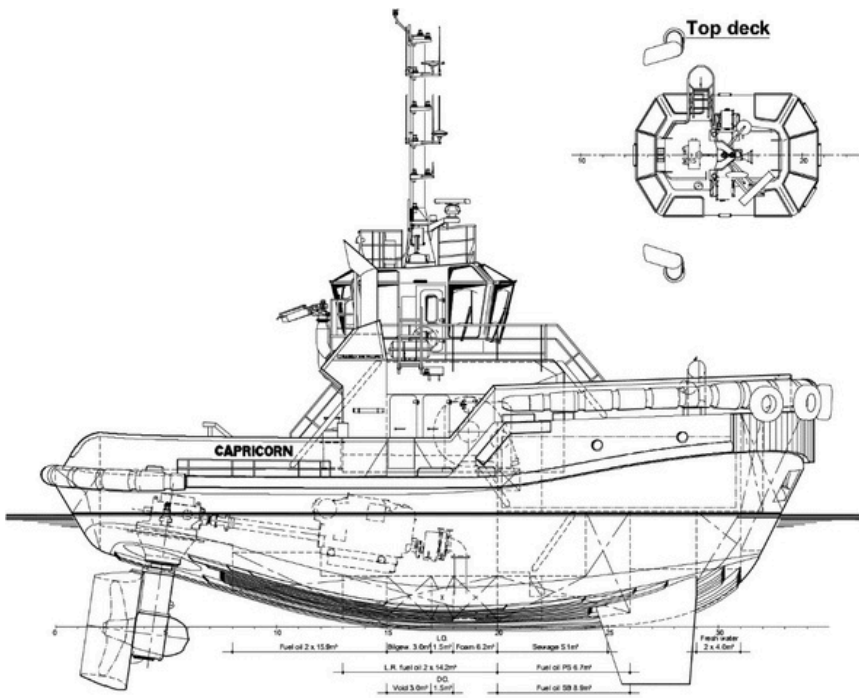

Main deck

Forecastle deck

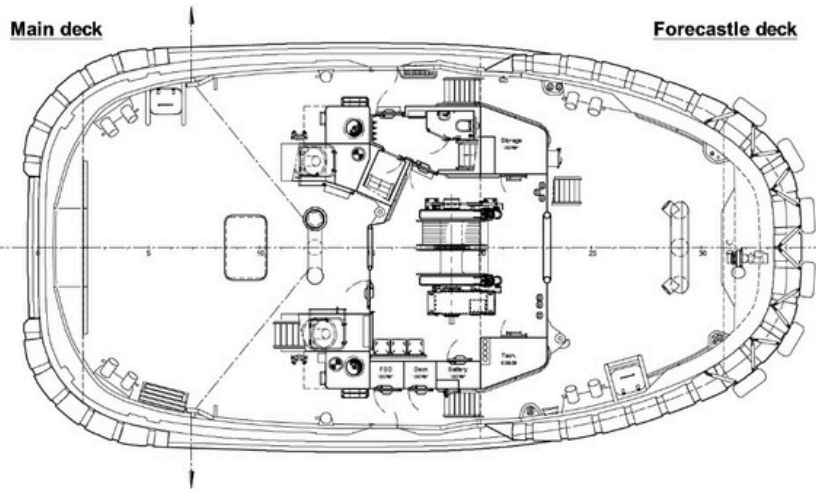

Bridge deck

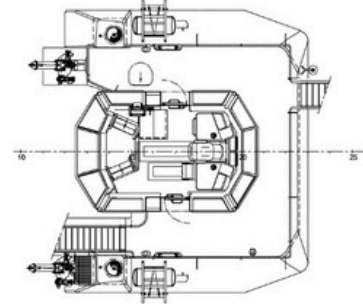

Below Main deck

Lower deck

Accommodation deck

